

Roof Deck Constructions  
**Construction No. 529**  
November 06, 2018  
**Uplift — Class 90**  
**Fire Not Investigated**

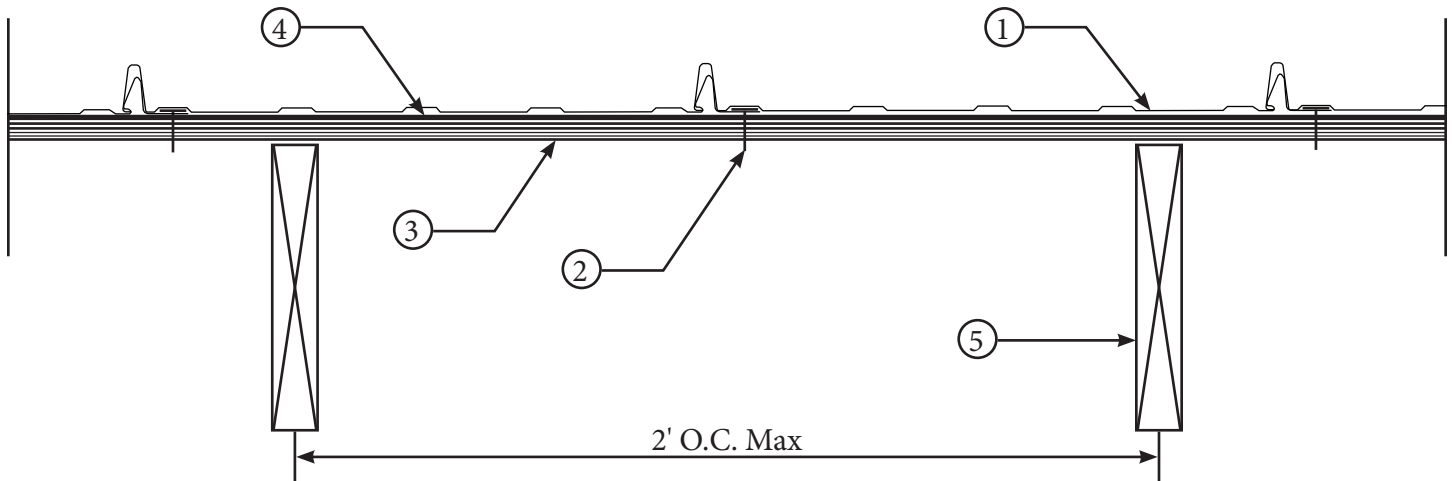

**MENARDS/MIDWEST MFG — “Pro-Snap”**

1. **Metal Roof Deck Panels\*** — No. 29 MSG min coated steel. Max panel width 24 in. Rib height nominal 1 in. Panels continuous over two or more spans. A bead of sealant may be used at panel endlaps.
2. **Fasteners — (Screws)** — For panel attachment to wood deck (Item 3), fasteners to be No. 10 x 1 in. long No. 2 Phillips, Pancake Head Type A. Fasteners spacing to be 12 in. OC with fasteners installed through prepunched slots in fastener flange of panel. For attachment of plywood deck (Item 3) to joists (Item 5), fasteners to be min. No. 6 by 1-7/8 bugle head screw or annular ring-shank nails. Spacing to be 6 in. OC at plywood edges and 12 in. OC at intermediate supports. When light gauge structural steel joists are used, fasteners to be No. 12 by 1-5/8 in. long with a Phillips head.
3. **Substructure — (Plywood)** — Plywood decking to be a nom 5/8 in. thick, exposure sheathing span C-D, 40/20 plywood. All butt joints to be sealed against leakage by using tape and/or caulk or with one-part urethane sealant.
4. **Moisture Barrier — (Optional)** — Any suitable membrane to protect substructure (Item 3).
5. **Joists** — Joists spaced at 2 ft, 0 in. OC, may be one of the following:
  - A. Nom 2 by 6 in. wood joists No. 2 or better.
  - B. Nom 2 by 4 in. wood when used on a top cord of a wood truss, No. 2 or better.
  - C. Light gauge structural steel framing with the member against the plywood to be a min No. 22 MSG coated steel.

Refer to General Information, Roof Deck Construction, (Roofing Materials and Systems Directory) for Items Not Evaluated.

\* Indicates such products shall bear the UL or cUL Certification Mark for jurisdictions employing the UL or cUL Certification (such as Canada), respectively.